

橋本スプロケット  
標準スプロケット  
(軸穴仕上げ品)

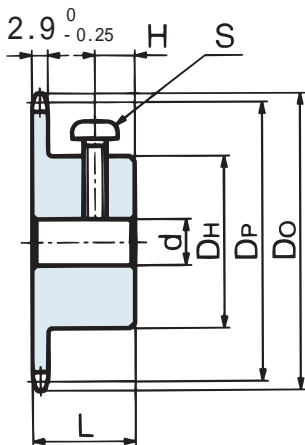

歯数	基本寸法		スプロケット型番	穴径 d	ハブ			止めネジ S	概略質量 (g)	価格 (円)
	ピッチ円直径 D <sub>p</sub>	(外径) 円径 D <sub>o</sub>			径 D <sub>H</sub>	長さ L	位置 H			
10	20.55	23.5	RS25 1B10T 8	8	13	14	4	M3 x 6	13	305
11	22.54	25.5	RS25 1B11T 8	8	15	14	4	M3 x 8	16	326
12	24.53	27.5	RS25 1B12T 8	8	17	14	4	M4 x 8	20	347
13	26.53	29.5	RS25 1B13T 8	8	18	14	4	M4 x 8	23	368
14	28.54	31.5	RS25 1B14T 8	8	19	14	4	M4 x 8	26	378
15	30.54	33.5	RS25 1B15T 8	8	20	14	4	M4 x 10	31	389
16	32.55	35.5	RS25 1B16T 8	8	21	16	5	M4 x 10	38	410
17	34.56	37.5	RS25 1B17T 8	8	23	16	5	M4 x 10	45	420
18	36.57	39.5	RS25 1B18T 8	8	25	16	5	M4 x 12	52	441
19	38.58	41.5	RS25 1B19T 8	8	26	16	5	M4 x 12	60	462
20	40.59	43.5	RS25 1B20T 8	8	28	16	5	M4 x 14	68	473
21	42.61	45.5	RS25 1B21T 8	8	30	18	7	M4 x 14	80	483
22	44.62	47.5	RS25 1B22T 8	8	30	18	7	M4 x 14	84	504
23	46.63	49.5	RS25 1B23T 8	8	30	18	7	M4 x 14	88	525
24	48.65	51.5	RS25 1B24T 8	8	30	18	7	M4 x 14	93	546
25	50.66	53.5	RS25 1B25T 8	8	30	18	7	M4 x 14	98	578
12	24.53	27.5	RS25 1B12T10	10	17	14	4	M4 x 8	20	347
13	26.53	29.5	RS25 1B13T10	10	18	14	4	M4 x 8	23	368
14	28.54	31.5	RS25 1B14T10	10	19	14	4	M4 x 8	26	378
15	30.54	33.5	RS25 1B15T10	10	20	14	4	M4 x 10	31	389
16	32.55	35.5	RS25 1B16T10	10	21	16	5	M4 x 10	38	410
17	34.56	37.5	RS25 1B17T10	10	23	16	5	M4 x 10	45	420
18	36.57	39.5	RS25 1B18T10	10	25	16	5	M4 x 12	52	441
19	38.58	41.5	RS25 1B19T10	10	26	16	5	M4 x 12	60	462
20	40.59	43.5	RS25 1B20T10	10	28	16	5	M4 x 14	68	473
21	42.61	45.5	RS25 1B21T10	10	30	18	7	M4 x 14	80	483
22	44.62	47.5	RS25 1B22T10	10	30	18	7	M4 x 14	84	504
23	46.63	49.5	RS25 1B23T10	10	30	18	7	M4 x 14	88	525
24	48.65	51.5	RS25 1B24T10	10	30	18	7	M4 x 14	93	546
25	50.66	53.5	RS25 1B25T10	10	30	18	7	M4 x 14	98	578
26	52.68	55.8	RS25 1B26T10	10	30	18	7	M4 x 14	98	588
28	56.71	59.8	RS25 1B28T10	10	30	18	7	M4 x 14	103	641
30	60.75	63.9	RS25 1B30T10	10	30	18	7	M4 x 14	110	672
32	64.78	67.9	RS25 1B32T10	10	30	18	7	M4 x 14	117	714
26	52.68	55.8	RS25 1B26T12	12	30	18	7	M4 x 14	98	588
28	56.71	59.8	RS25 1B28T12	12	30	18	7	M4 x 14	103	641
30	60.75	63.9	RS25 1B30T12	12	30	18	7	M4 x 14	110	672
32	64.78	67.9	RS25 1B32T12	12	30	18	7	M4 x 14	117	714
仕様材	鉄系焼結合金									

注) 軸穴径は公差 H8

チェーン

